

FLOOR LOADING CONSIDERATIONS

H I G H - D E N S I T Y M O B I L E S T O R A G E



INTRODUCTION

Most Architects and Structural Engineers are aware of Spacesaver high-density mobile storage systems. Spacesaver systems are universally recognized by all sectors of users desiring the advantages of functional utility, higher storage density, cost savings and space conservation.

Spacesaver high-density mobile storage systems offer Planners a broad selection of system configurations in standard sizes, while Spacesaver's unique flexibility allows customization for specific applications. Spacesaver can provide choices of standardized systems and data to accommodate special conditions for existing buildings and new construction.

For all existing buildings, Spacesaver recommends that a Structural Engineer be commissioned to analyze the building's structural system and ensure it can safely support code-imposed gravity loads and, if required, seismic loads. A Structural Engineer can analyze existing structures and, if necessary, provide details on structural retrofitting. For new construction, a Structural Engineer can help select efficient structural framing details for supporting Spacesaver high-density mobile storage systems. For a recommendation of an independent Structural Engineer, contact your Spacesaver Area Contractor.

This guidebook has been prepared as an introduction to floor loading, when considering Spacesaver high-density mobile storage systems. Spacesaver Engineering Staff and Spacesaver Area Contractors will be pleased to discuss any questions you might have on floor loading or structural retrofitting.



THE CONCEPT

Spacesaver high-density mobile storage systems maximize square-foot capacity for storage and filing by providing movable storage shelves and movable aisles instead of fixed shelves and fixed aisles. Mobilized units permit high-density space utilization and quick access as needed.

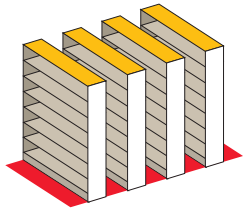

1. Conventional arrangement of fixed shelving units and fixed aisles.

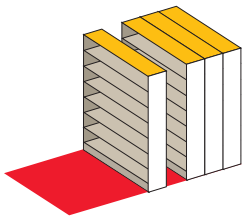

2. Elimination of non-productive fixed aisles compacts material and saves 50% of space for other functions.

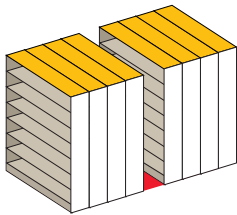

3. Or, 100% more storage capacity can be added within the same space.

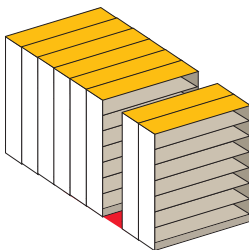

4. System flexibility & orientation can be adjusted to meet any storage density and floor-loading objectives.

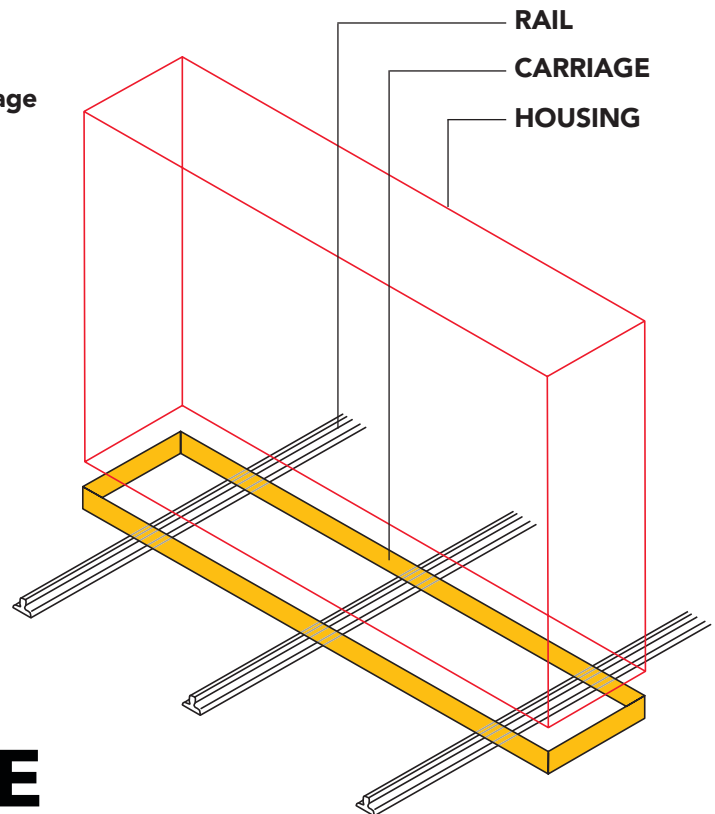

THE CARRIAGE

Illustrated is the versatile Spacesaver carriage, the heart of all Spacesaver system designs. It accommodates any type of new or existing shelving, cabinets or other storage equipment. The wheel-based carriage frames ride on the steel rails. Transferring the loads to building structure may be accommodated by altering rail size, rail spacing and rail orientation.

WELDED UNIFRAME CONSTRUCTION Fabricated steel profiles are welded to form solid "uniframe" construction. The shapes of "uniframe" members are designed to provide exceptional rigidity. Welding results in minimal distortion and keeps carriage members structurally square and true under heavy loads.

NEW CONSTRUCTION

The magnitude of floor-load capacity required will be contingent on type of media stored, number of tiers of shelving, and type of floor system. Typical floor design load requirements for paper files and books are 125-200 psf (pounds per square foot). Other applications, such as museums, may require 275-300 psf, depending on number of tiers of shelving and type of floor system.

IMPORTANT: Contact your local Spacesaver Area Contractor for information concerning required loading capacities and best recommendation for the type of floor system.

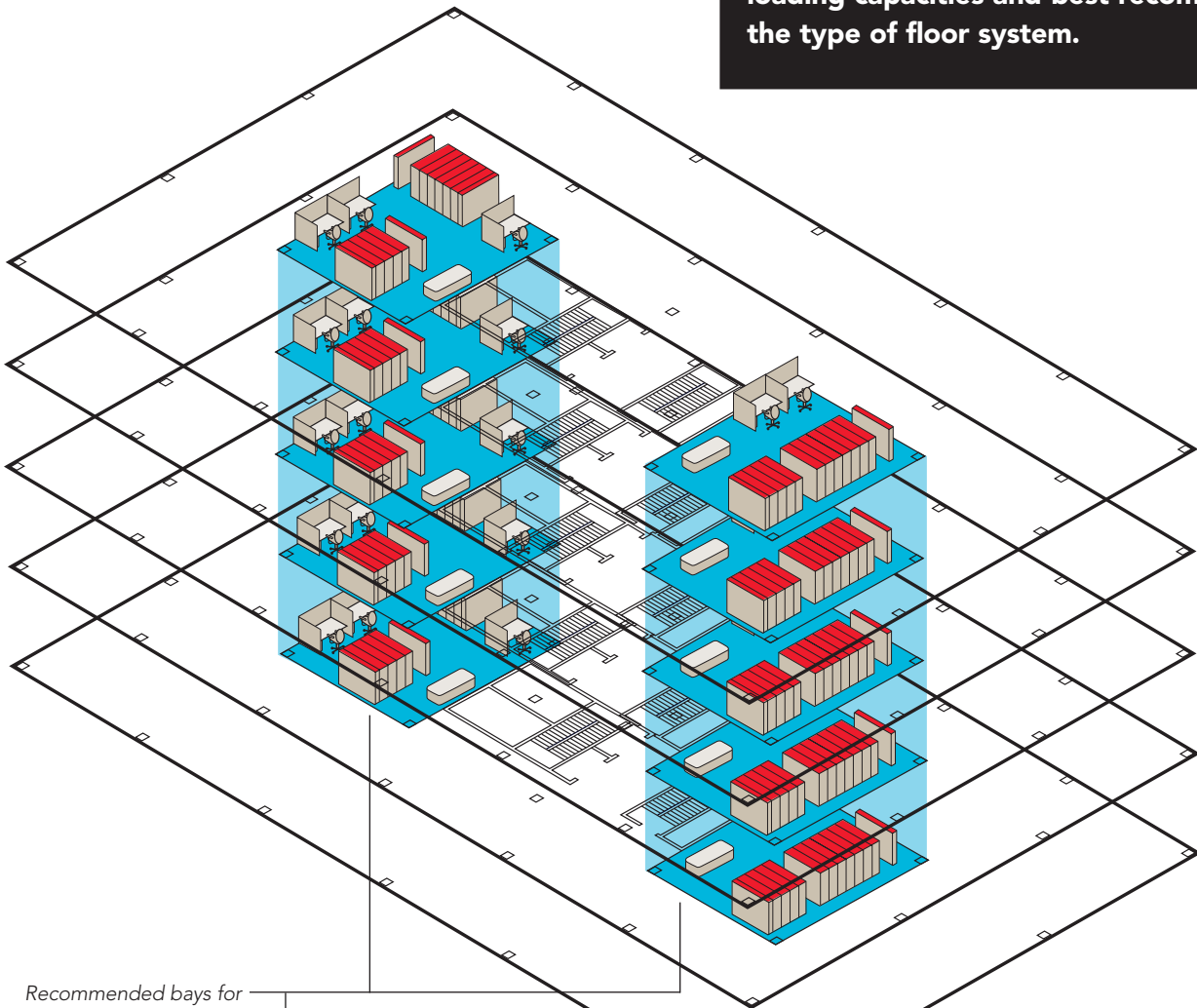

Recommended bays for accommodating Spacesaver high-density mobile storage systems near building's core.

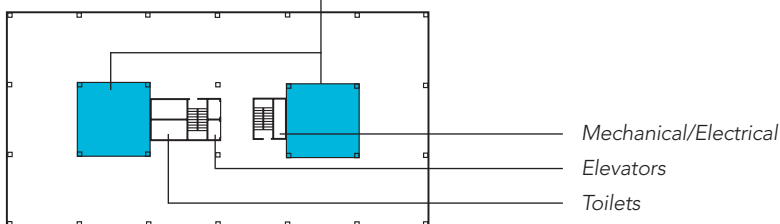

FLOOR LOADS IMPOSED

The weight of Spacesaver high-density mobile storage systems does not transfer equally underneath the footprint of the Spacesaver system. **This load transfers as a line load at the rail locations.** Although unit load in pounds per square foot (psf) is an indicator of floor capacity, individual line loads should also be reviewed by an independent Structural Engineer. Example: If the average unit load of a Spacesaver system is 125 psf and the rails are spaced on five-foot centers, this would be $125 \text{ psf} \times 5 = 625 \text{ plf}$ (**pounds per linear foot**) line load as illustrated below. The line load magnitude will vary depending upon the spacing of rail locations and number of rails per carriage.

TOTAL SYSTEM LOADS – Codes require that file and computer rooms be designed for heavier loads based on anticipated occupancy. Weight of Spacesaver system must include carriage, rail, housing, and media stored in the system. Due to the relatively slow movement of carriages and controlled acceleration and deceleration, impact loads to the floor structure are negligible and need not be considered for Spacesaver high density mobile storage systems.

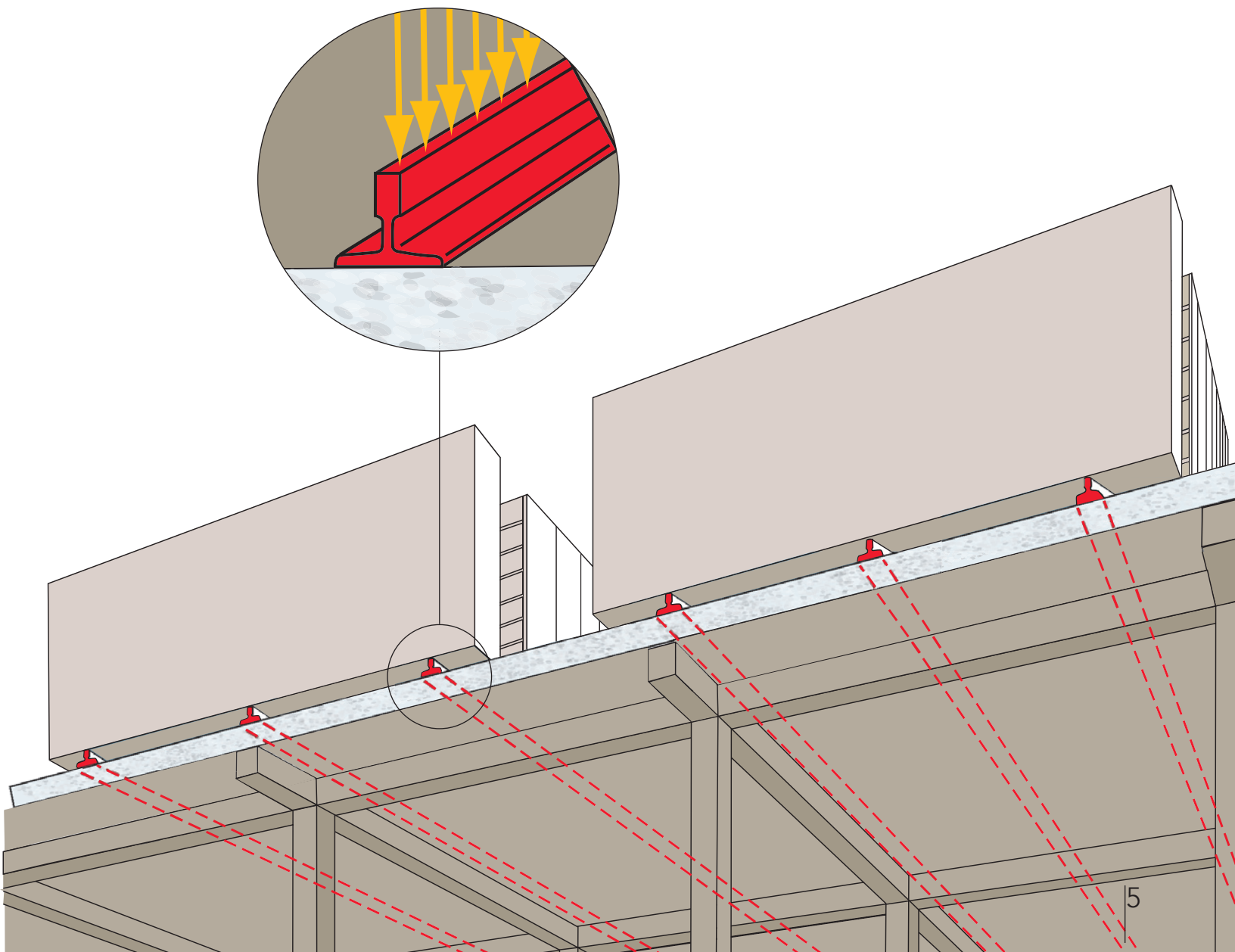

RAIL LAYOUT FLEXIBILITY

Even distribution of the heaviest floor loads is accomplished through flexibility of the Spacesaver rail layout. The Engineer is free to locate rails at practical load-bearing points (rails can be located in any increment between 3' and 7' as standard) or as required by specific applications to meet load conditions or overcome structural constraints. Typical rail layouts and variations are illustrated at right. Physical properties of the rail sections and lengths of rail may be selected to accommodate various structural conditions. (See enclosed tables under "Rail Data" on page 14).

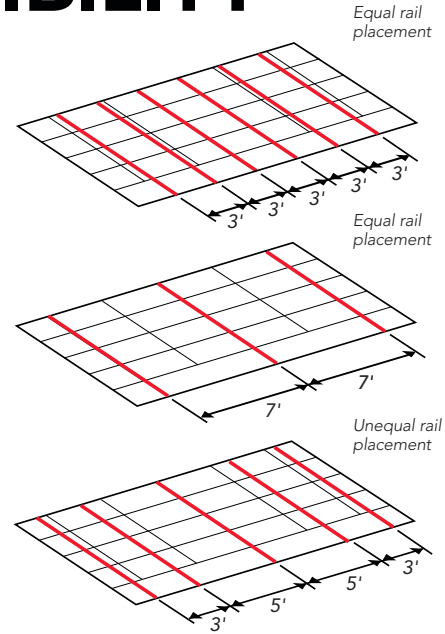

STANDARD RAIL PLACEMENT

The flexibility of the Spacesaver rail system allows the Designer a full selection of options for distributing the imposed floor loads. By adjusting rail placement and spacing, increased loads may be accommodated. As illustrated above, variations of normal rail placement allow load points to be relocated, thereby affecting new load distribution. Refer to the chart below for standard rail placement.

Spacesaver Systems – Series DF, CF, RG

Carriage Length (Feet)	Number of Rails	*Standard Overhangs in Inches	*Standard Rail Centers, Inches	
			Manual & Mechanical Assist	Powered
3	2	6"	24	24
3-1/2	2	6"	30	30
4	2	6-9"	30	30
6	2	6-18"	48	48
7	2	6-18"	60	60
8	2	6-24"	72	72
9	2	6-24"	72	72
10-1/2	3	6-24"	45	45
12	3	6-24"	54	54
16	3	6-24"	78	78
18	4	6-24"	60	60
21	4	6-24"	72	72
24	5	6-24"	63	63
27	5	6-24"	72	72
30	5	6-24"	81	81
33	6	6-24"	72	72
36	6	6-24"	1 @ 80-4 @ 79	1 @ 80-4 @ 79
39	7	6-24"	72	72
42	7	6-24"	78	78
45	8	6-24"	72	72
48	8	6-24"	-	1 @ 78-6 @ 77
51	8	6-24"	-	2 @ 83-5 @ 82
54	9	6-24"	-	4 @ 77-4 @ 76
57	9	6-24"	-	81
60	10	6-24"	-	76
63	10	6-24"	-	80
66	11	6-24"	-	6 @ 76-4 @ 75
69	11	6-24"	-	2 @ 80-8 @ 79
72	12	6-24"	-	3 @ 76-9 @ 75
75	12	6-24"	-	6 @ 79-5 @ 78
78	13	6-24"	-	75
81	13	6-24"	-	78

*Consult your local Spacesaver Area Contractor for overhangs and rail centers outside this range.
NOTE: For heavy-duty industrial systems, consult factory.

LOAD FOOTPRINTS

The **Impact Area Footprint** is the combined area of the storage system plus aisles. Loads from the shelves are transferred to the carriage frame, which then transfers the loads to the wheel assembly and individual wheels. The wheels transfer the loads as point loads to the rails, which transfer the loads to the structure. The aisles are subjected to pedestrian loads (15 psf minimum) which must be considered in conjunction with the storage system loads. The total load within the **Impact Area Footprint** is a combination of the storage system loads and aisle loads. The area outside the **Impact Area Footprint** is subjected to the loads required by the building occupancy.

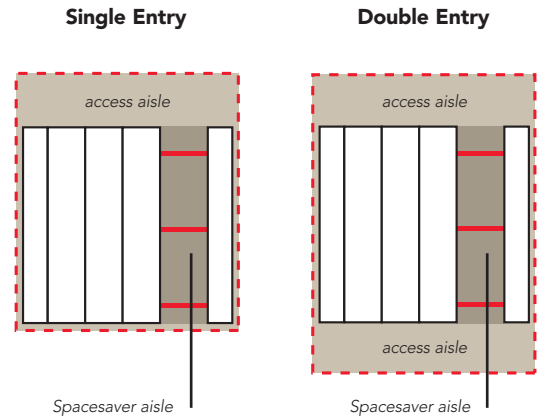

RAIL LOAD DISTRIBUTION

Normally, Spacesaver high-density mobile storage systems are planned with rail placement for approximately equal rail loads. However, the Designer may choose to develop unequal rail loading if conditions are more advantageous for load transfer. In most applications, equal loads are desirable.

*Actual load depends on carriage frame cantilever.

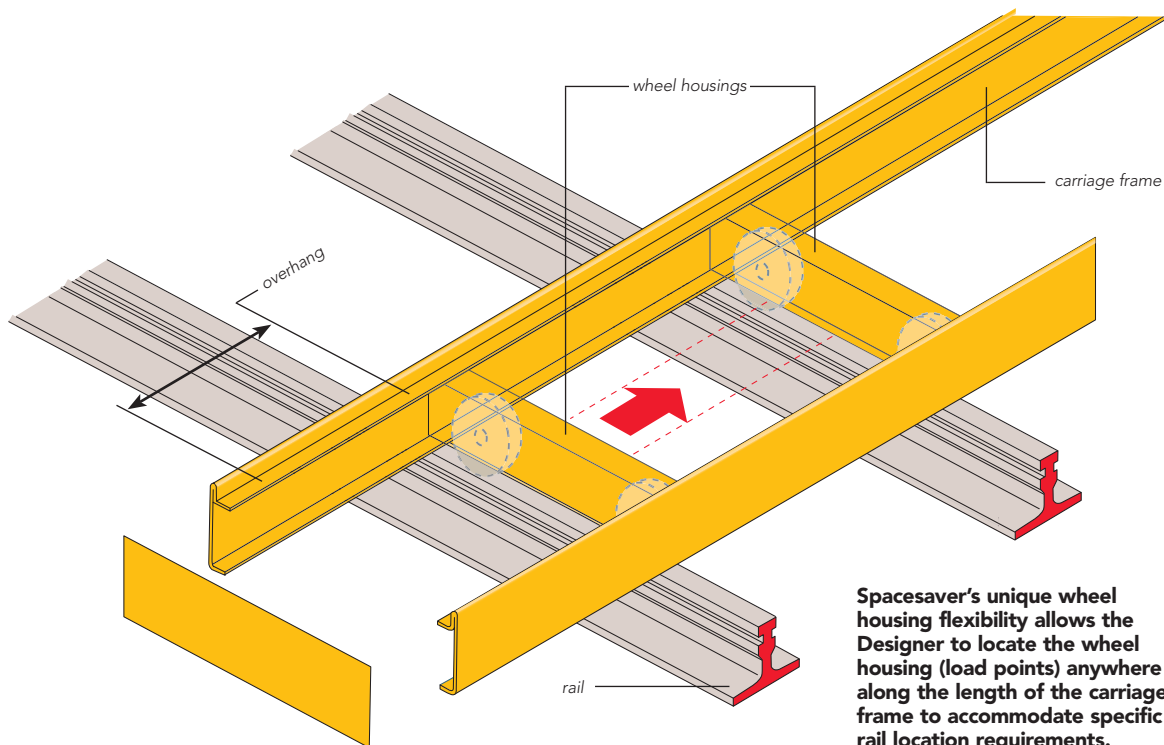
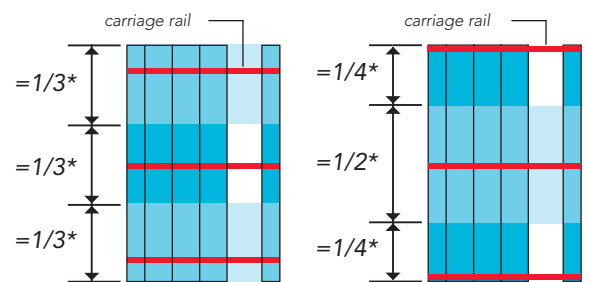

Spacesaver's unique wheel housing flexibility allows the Designer to locate the wheel housing (load points) anywhere along the length of the carriage frame to accommodate specific rail location requirements.

PREFERRED ORIENTATION

When evaluating floor loads imposed by Spacesaver systems, initial layouts may yield conditions not meeting your exacting criteria. However, because of Spacesaver's rail size selections and their unique ability to be reoriented directly over load-bearing points, satisfactory loading may be accomplished.

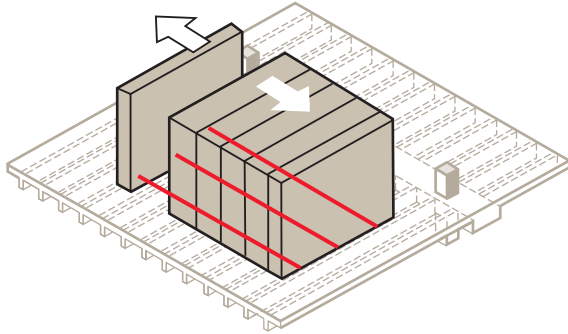

1. Rails placed perpendicular to structural members

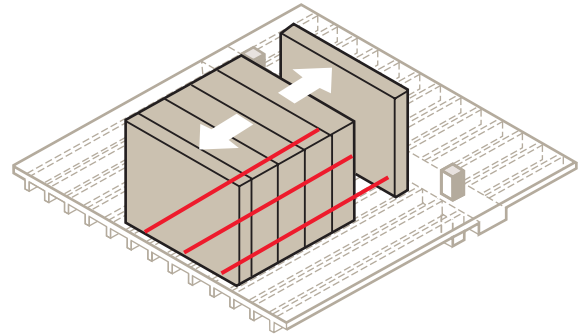

2. Rails placed parallel to structural members (coincide with joists)

RELOCATION OF SYSTEMS

Occasionally, a system's weight may be greater than a bay's allowable load capacity. For example, placement of a system weighing 44,000 lbs. into a bay designed for only 40,000 lbs. may require repositioning the system directly over a girder between the adjacent bay and adding a fourth rail. (See illustration.) Thus, 22,000 lbs. is carried by each bay allowing the remaining space to be utilized for conventional office use.

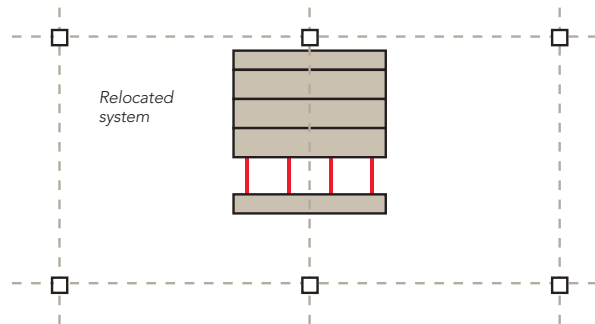
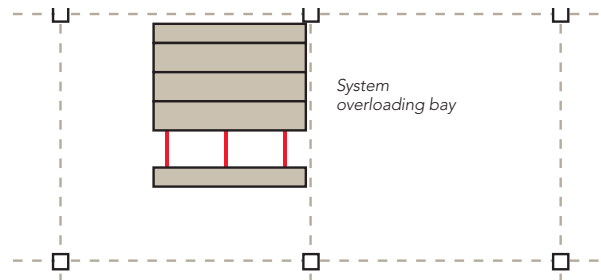

CANTILEVER VARIATIONS

Carriages may be cantilevered beyond their initial support point and/or last support point in order to transfer load to a structural member. The median cantilever is 18 inches which may be increased or decreased to meet special requirements.

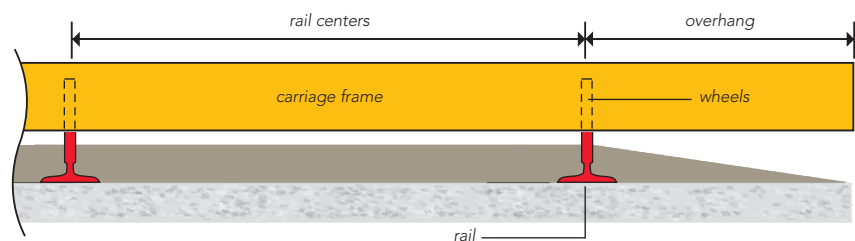

TYPICAL FLOOR CONDITIONS

Illustrated below are typical floor-loading conditions with ideal rail placements.

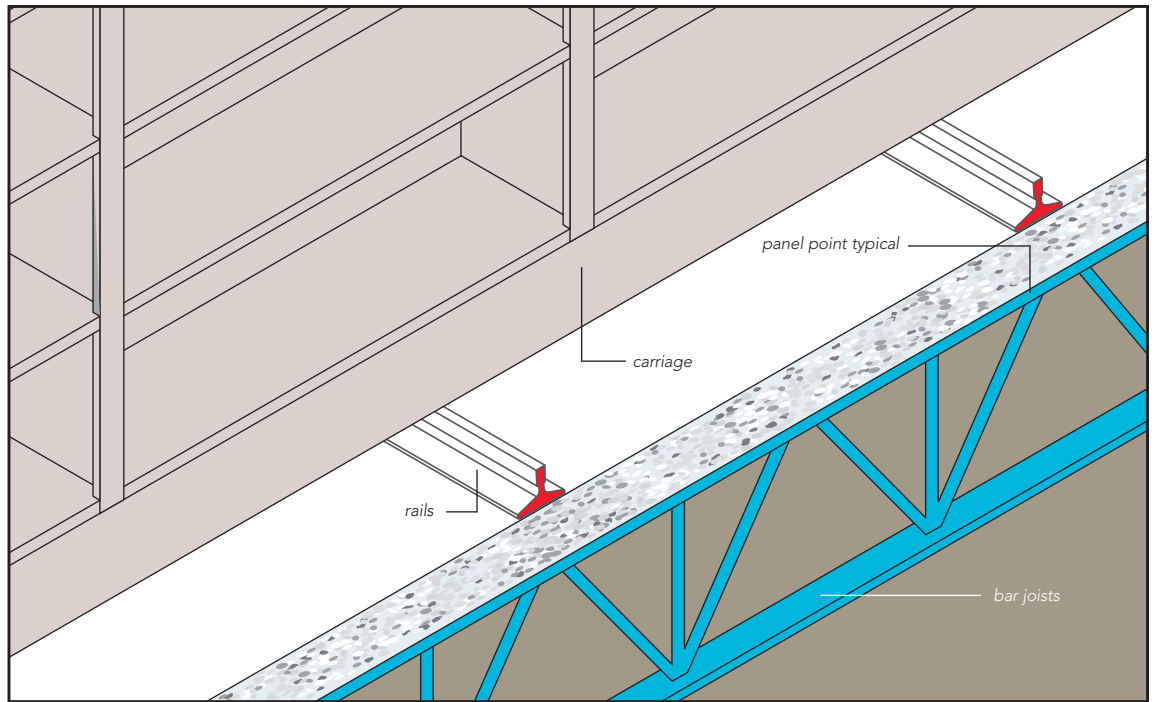

BAR JOIST FLOOR

When possible, system rails should be placed above the bar joist's top chord panel points to obtain maximum load-carrying capacity.

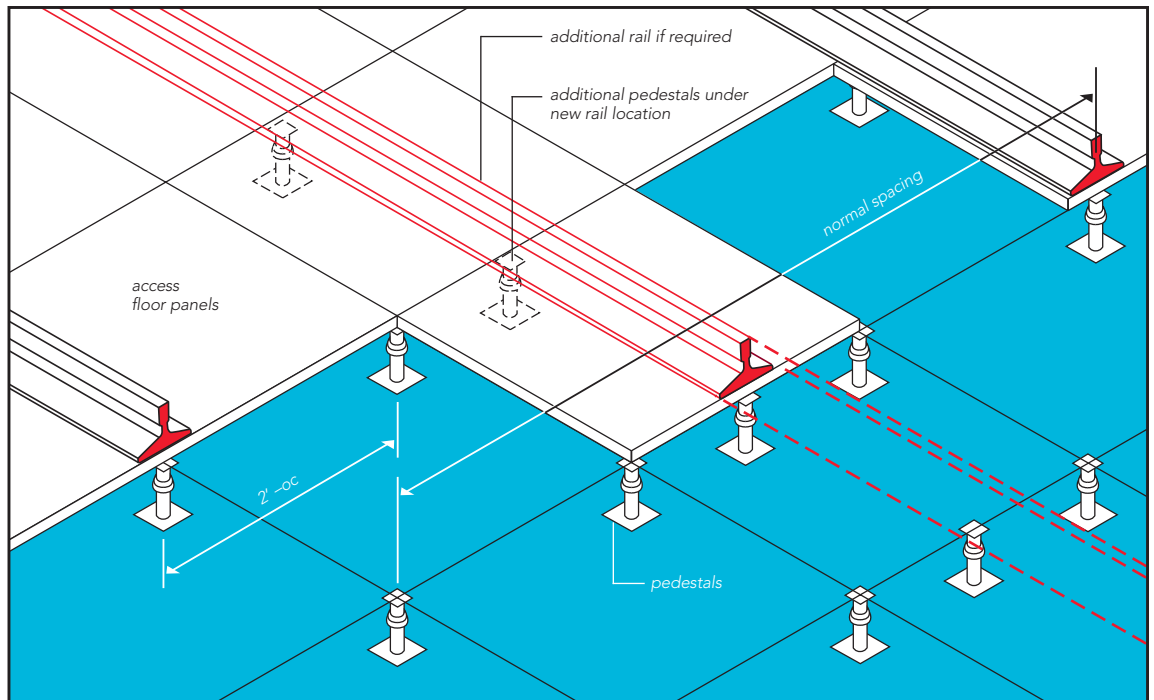

ACCESS FLOOR

For installations involving access floors, rail placement should be designed to fall directly over access floor pedestals. If rail placement does not coincide with pedestals, we suggest additional pedestals be placed directly under new rail location (see added rail in illustration). In some instances, a larger rail size precludes the need for additional pedestals. Seismic pedestals may be used when necessary.

POST CONSTRUCTION

STRUCTURAL MODIFICATIONS & SUPPLEMENTS

BEAM SUPPORT PERPENDICULAR TO BEAMS (LOOKING UP)

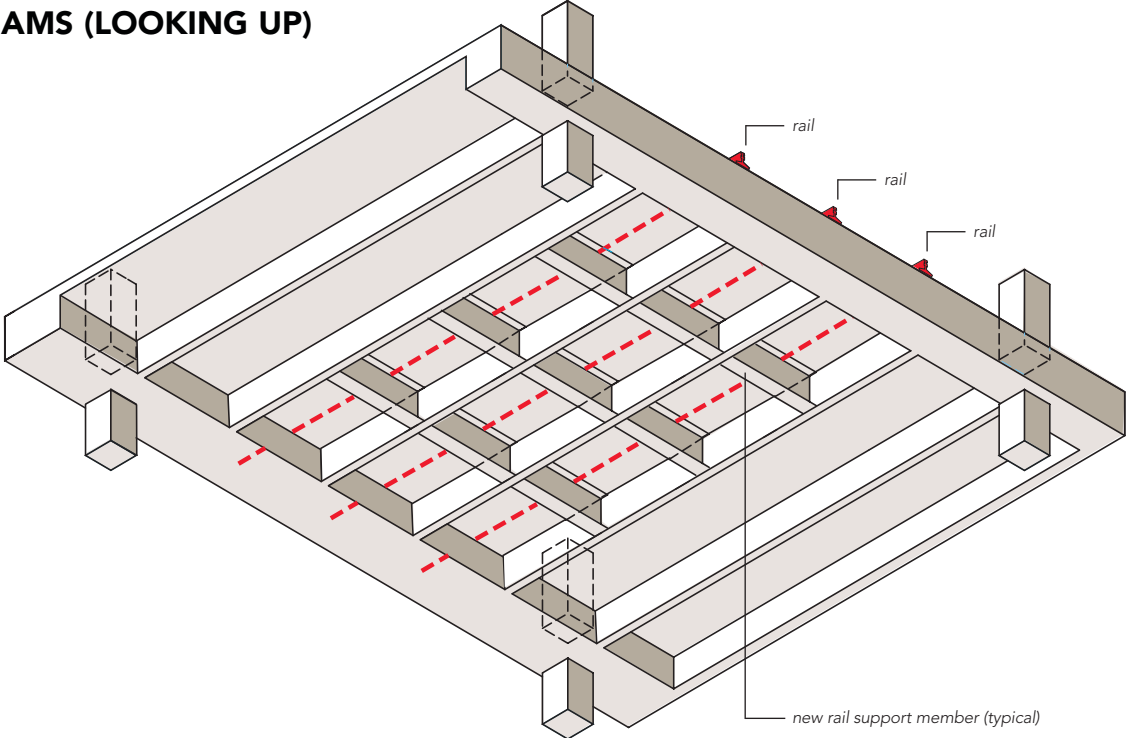

JOISTS REINFORCED WITH CARBON FIBER REINFORCING (LOOKING UP)

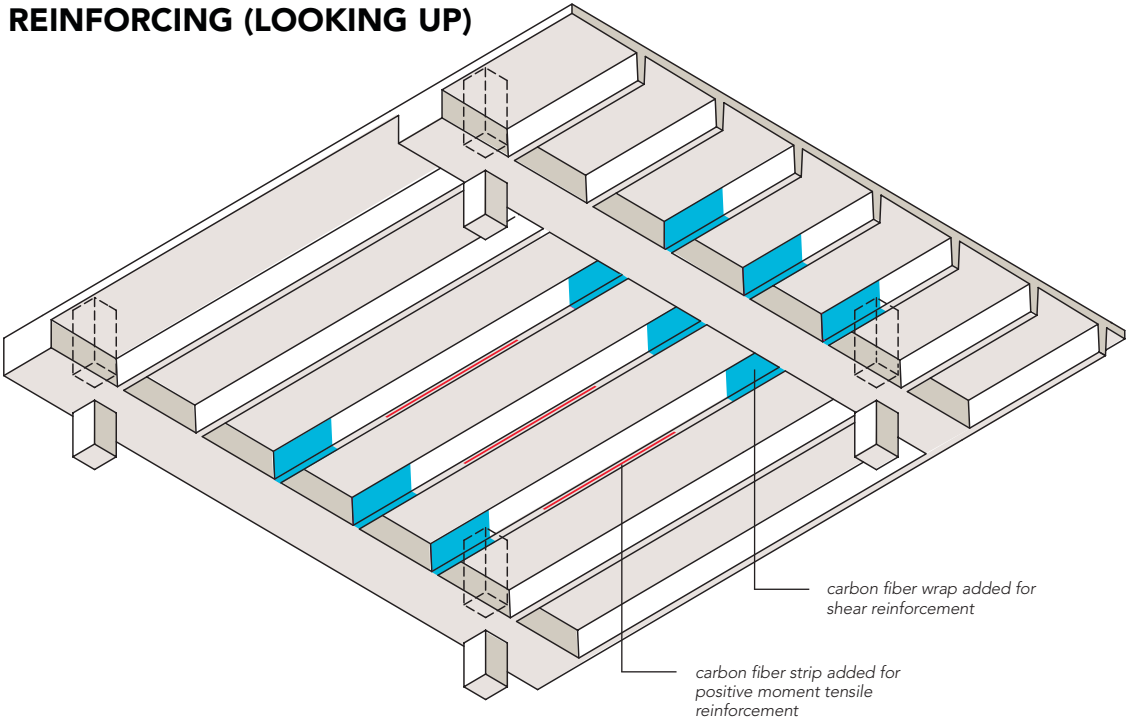

STRUCTURAL MODIFICATIONS & SUPPLEMENTS (CONTINUED)

JOISTS REINFORCED WITH CARBON FIBER REINFORCING

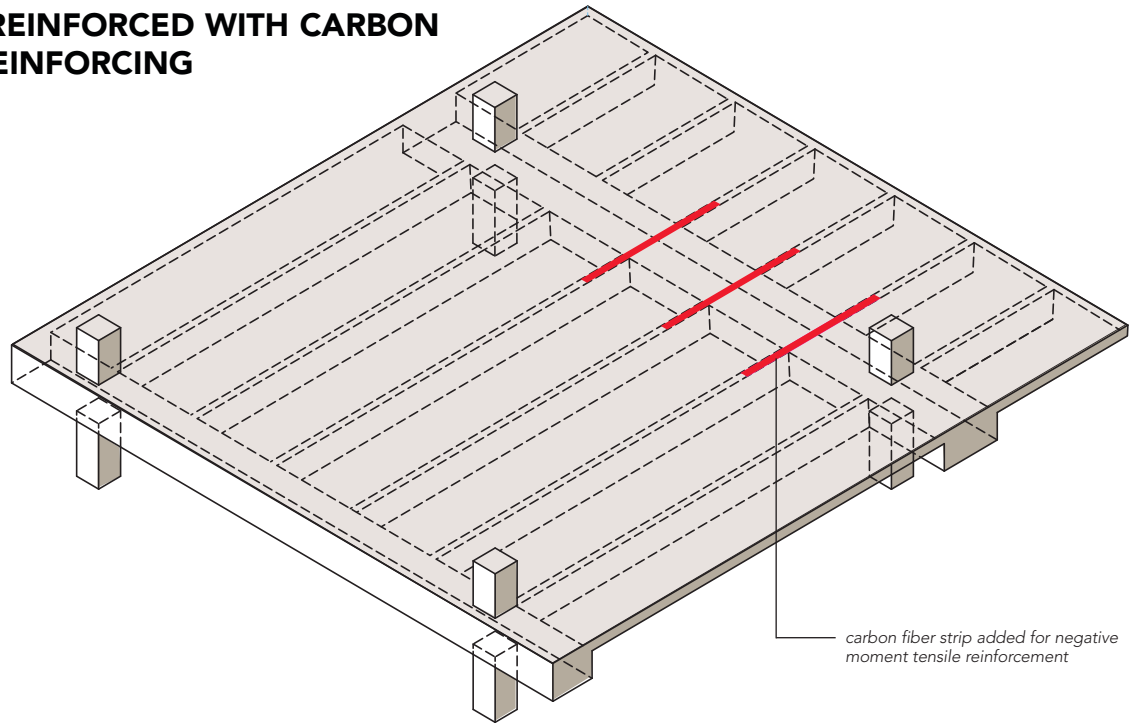

COLUMN AND/OR WALL ADDITIONS

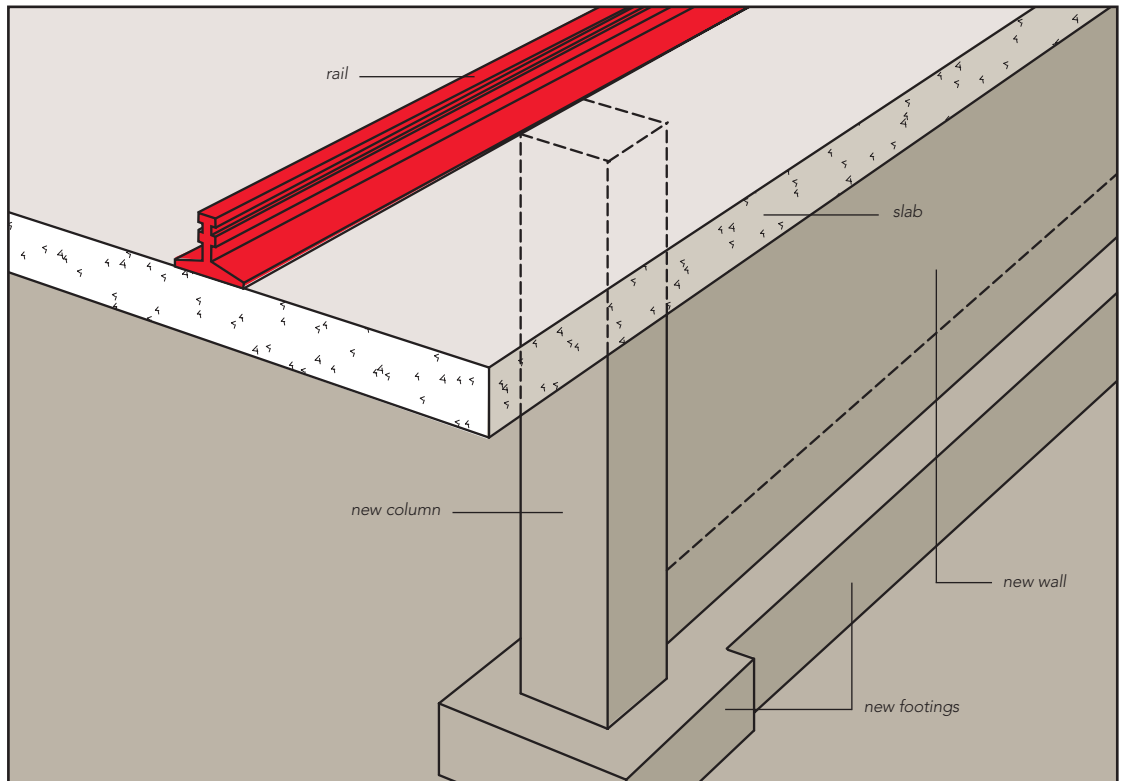

POST CONSTRUCTION

STRUCTURAL MODIFICATIONS & SUPPLEMENTS (CONTINUED)

GRILLAGE DETAIL WITH RAILS PARALLEL TO BEAMS GRILLAGE

Locate rails on top of grillage
(rails not shown).

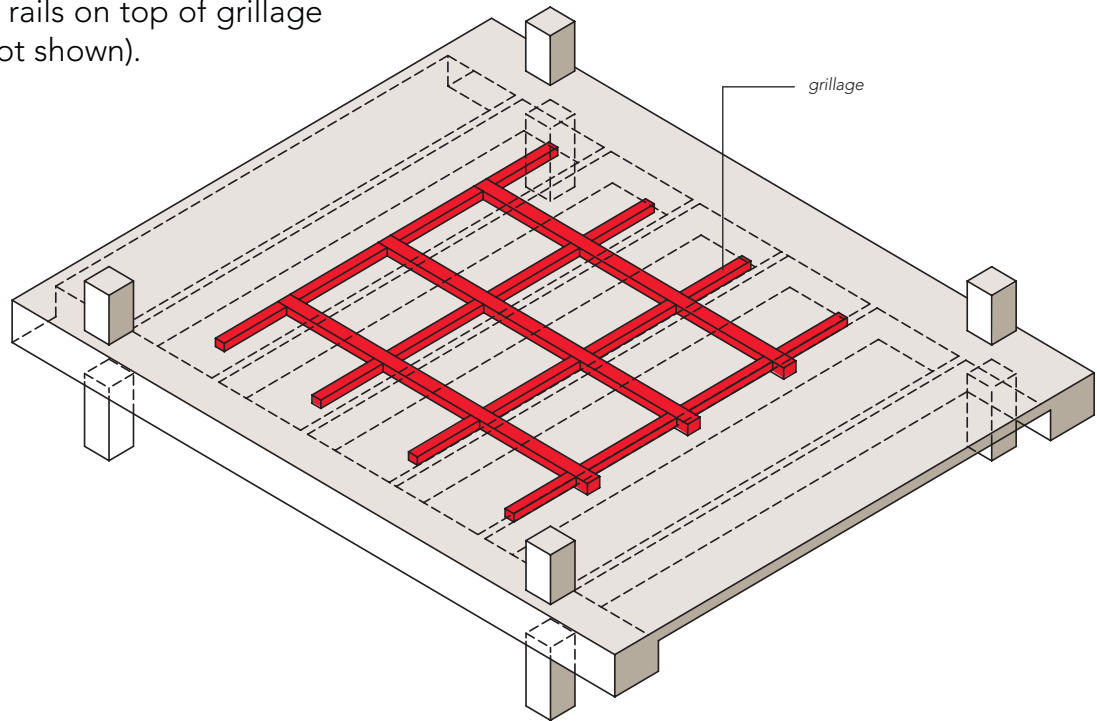

JOISTS REINFORCED WITH REINFORCING STEEL AND CARBON FIBER REINFORCING (LOOKING UP)

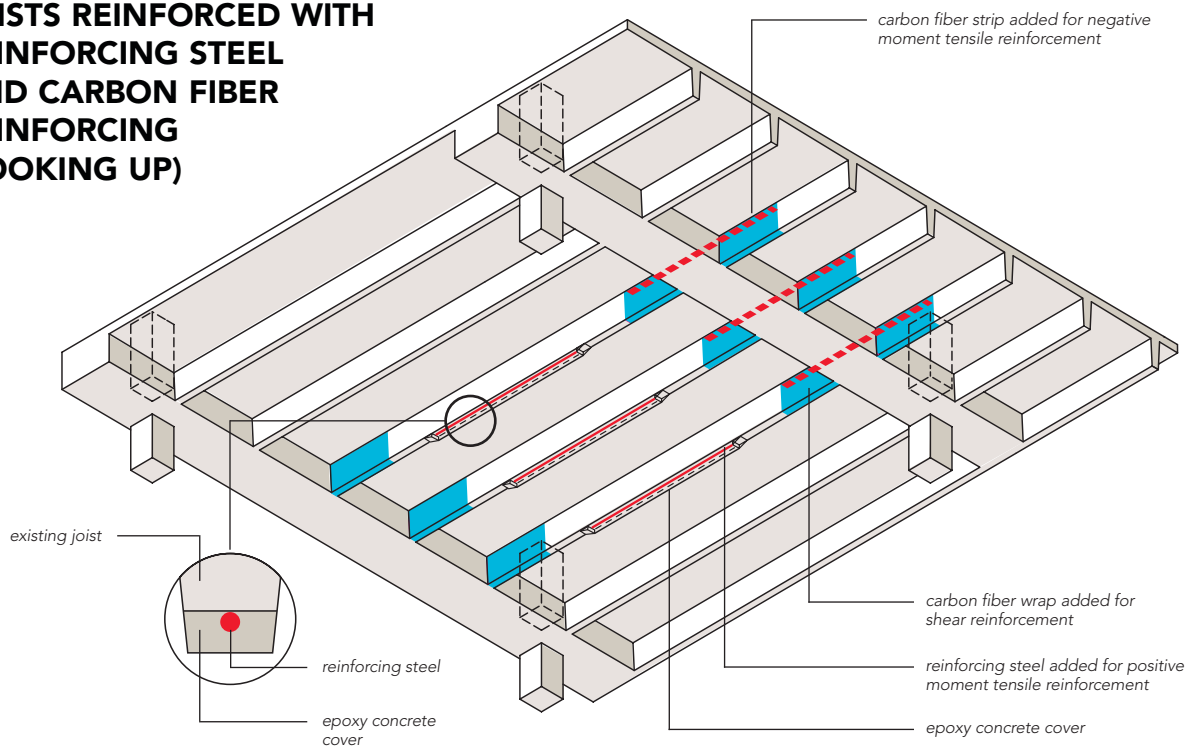

POST CONSTRUCTION

SUSPENDED SYSTEMS

Suspension systems employ shop-fabricated overhead beams bolted in the field and connected to existing building columns. Suspension hangers are dropped from these beams to carry the load, thereby transferring the weight of the mobile system to the existing columns. Overhead beams are fabricated in sections with moment connections to simplify erection and delivery into the building through existing doors and elevators.

1. Shop-fabricated overhead beams connected to building columns.

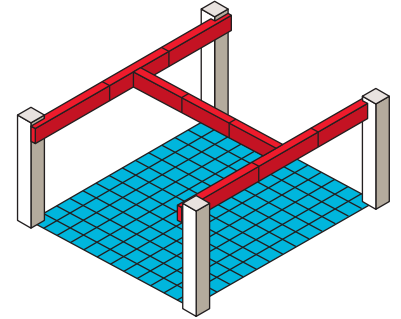

2. Suspension hangers dropped from beam.

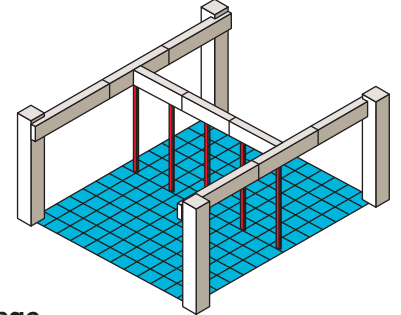

3. Stationary storage range installed around hangers.

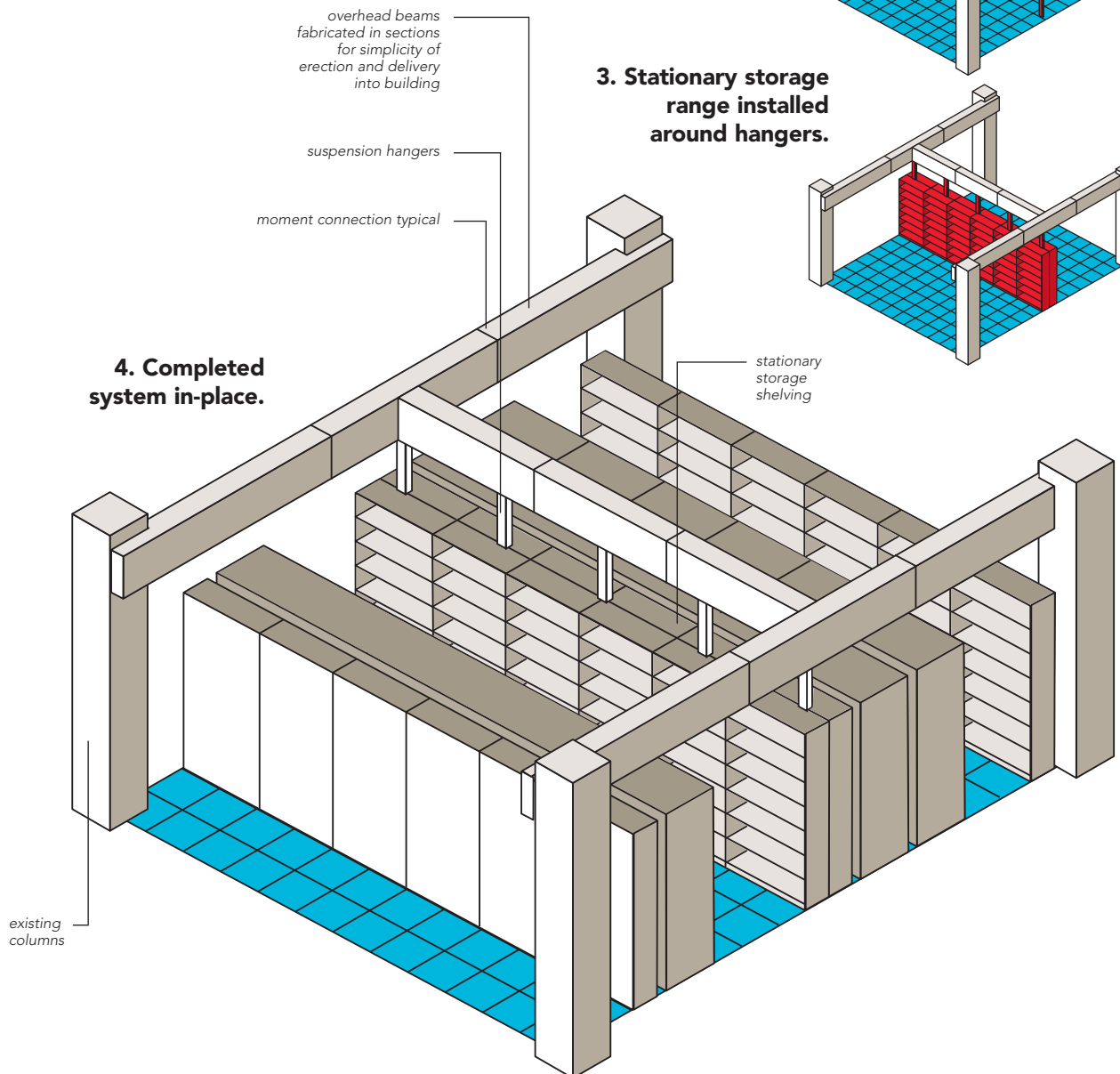
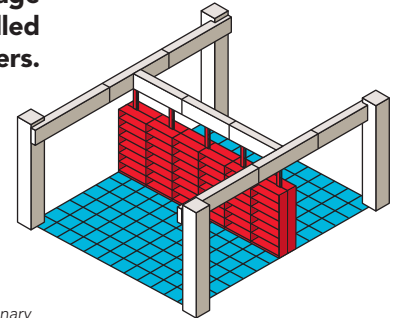

RAIL DATA

Structural steel rails are machined smooth at top and side contact points. Rail joints may be tongue and groove, and may be spliced along any point above bearing structural members. Dimensions and section properties are charted on this page.

NOMINAL DIMENSIONS (INCHES)

RAIL	Wt/Ft (lbs)	A	B	C	D	E	SYSTEM USAGE
RL001*	4.0	11/16	1-11/16	5/8	-	-	DF
RL002*	5.0	3/4	3-7/16	5/8	-	-	DF
RL011**	3.2	1-1/16	2-1/8	5/8	3/8	1/4	DF, CF, RG
RL011C**	4.0	1-1/16	2-1/8	15/16	1/4	5/16	CF
RT161**	8.0	2-7/16	3-1/2	5/8	1-1/4	5/16	DF, CF, RG
T-709**	12.0	3-1/2	5	5/8	1-3/4	5/16	DF, RG
T-160**	15.0	3-1/2	5	5/8	1-31/32	1/2	DF, RG
T-171**	18.5	4-1/4	5-1/2	3/4	1-31/32	1/2	RG
T-169**	22.5	4	5-1/2	1-1/8	2	9/16	RG, CF
T-162**	30.0	5	5-1/2	1-1/4	2-1/4	11/16	RG, CF

* Rails RL001 and RL002 are 6' long and made of 1045 (cold rolled) steel and Rail RL005 is 8' long and made of 1045 (cold drawn) steel.
 **Rails are available in standard lengths of 8'. Rail shall be structural "T" section of AISI C-1035 (hot rolled) steel. Minimum tensile strength of rails is 70,000 psi. Yield strength is 50,000 psi.

SECTION PROPERTIES

RAIL	Wt/Ft (lbs)	A	\bar{y}	I_x	S_x (Top)	S_x (Btm)	r_x	I_y	S_y	r_y
RL001	4.0	.60	.32	.03	.07	.09	.21	.10	.12	.40
RL002	5.0	.94	.36	.06	.15	.16	.25	.96	.56	1.01
RL011	3.2	.94	.39	.11	.17	.28	.34	.21	.21	.48
RL011C	4.0	1.18	.39	.12	.18	.31	.32	.31	.29	.51
RT161	8.0	2.40	.81	1.40	.86	1.73	.78	1.28	.73	.74
T-709	12.0	3.51	1.08	4.49	1.85	4.16	1.13	3.61	1.45	1.01
T-160	15.0	4.41	.94	4.78	1.89	.09	1.04	5.51	2.21	1.12
T-171	18.5	5.44	1.26	9.67	3.23	7.67	1.33	7.45	2.71	1.17
T-169	22.5	6.73	1.38	11.17	4.20	8.09	1.28	8.64	3.10	1.13
T-162	30.0	8.93	1.74	24.00	7.37	13.80	1.64	11.08	4.03	1.11

A = Area in square inches
 \bar{y} = Distance from bottom of rail to axis x - x inches

I_x = Moment of inertia about axis x - x inches⁴
 S_x = Section modulus about axis x - x inches³
 r_x = Radius of gyration about axis x - x inches

I_y = Moment of inertia about axis y - y inches⁴
 S_y = Section modulus about axis y - y inches³
 r_y = Radius of gyration about axis y - y inches

FIELD WELDS

When field welding is required, it is recommended that all field welds be performed by a certified welder and be full penetration welds. (T-169 and T-162 rails require special welding procedures. Bolted splice recommended.)

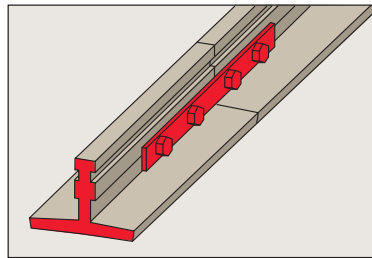

Shear connection for RT-161 rail

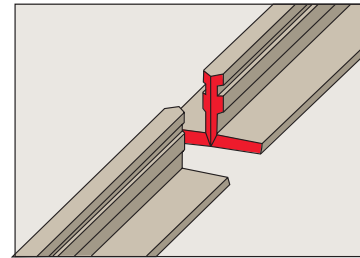

Full moment welded connection for RT-161 rail

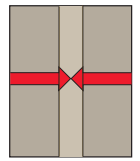

Plan View Full moment welded connection for RT-161 rail

STRUCTURAL DEFLECTIONS

All framed floor systems are subjected to deflection when load is applied to the floor system. The amount of deflection is proportional to the applied load. Buildings with large bays can have enough deflection, which could cause high-density mobile storage systems to drift.

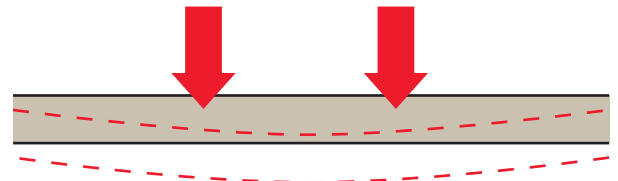

Maximum allowable deflection is expressed as “L” over a value; L=unsupported span (in inches) between beams. Spacesaver has developed a patented positioning brake, which will prevent systems from drifting.

- Manual / Mechanical Assist mobile systems are typically designed for L/700.
- Mechanical Assist mobile systems with clutch brake can achieve L/480
- Powered mobile systems are typically designed for L/480
- Powered mobile systems with automatic brake can achieve L/360

Your Area Contractor will assist you in determining maximum allowable deflection you can expect in the floor system and provide you with the proper positioning brake to prevent drifting.

SEISMIC LOADS

Current building codes require that “Building Components” such as high-density mobile storage systems, be designed to resist the code-required seismic forces in areas that may be prone to seismic activity. If you are located in such an area, special construction practices are required to resist the seismically induced forces and overturning moments.

Spacesaver has developed patented anti-tip systems, internal bracing and attachments within the shelving and carriage systems that meet all present code requirements. Your Area Contractor can assist you in selecting a suitable anti-tip, shelving and carriage system, as well as provide you with details for properly anchoring the rail system to the structural slab.

CASE STUDY

FIRST NATIONAL-SOUTHERN NATURAL GAS BUILDING

Birmingham, Alabama

Architects: Welton Becket & Associates, Houston, Texas

Spacesaver Area Contractor: Walter H. Hopkins Company, Atlanta, Georgia

Design Criteria Concentration of 47,000 filing inches of corporate documents weighing over 95,000 lbs. into a space of approximately 965 sq. ft. Layout must anticipate weight of high-density system and some existing shelving to comply with the structure designed for a live load of 100 psf. System used must have flexibility in rail layout to distribute heavy loads within Consulting Engineer's criteria of building safety allowances.

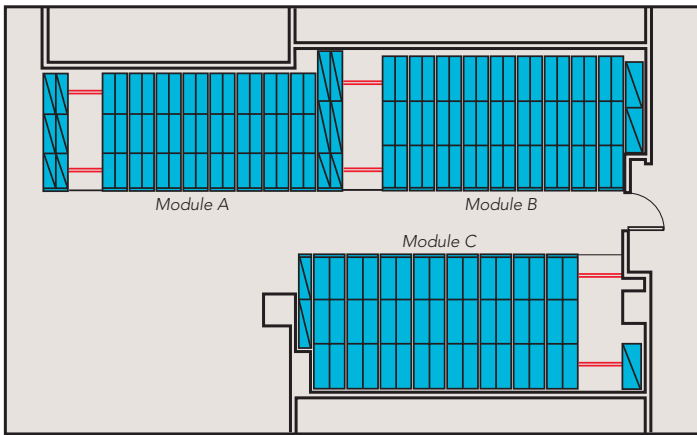

Floor Loading Analysis Preliminary layout (Scheme 1) had rails parallel to the floor-framing beams. Floor construction under Module "A" was a 3 inch concrete slab on metal decking supported on steel framing. The 3 inch slab could not support the load. Through close collaboration between the building's consulting Structural Engineers and Spacesaver personnel, it was determined that the Module "A" unit be turned 90° so that rails spanned three floor beams. Further, it was determined that additional rails for Modules "B" & "C" would be necessary to be within safe limits for the floor construction. A final revised layout (Scheme 2) resulted. The rail spacing flexibility of the Spacesaver system allowed proper distribution of loads over building members.

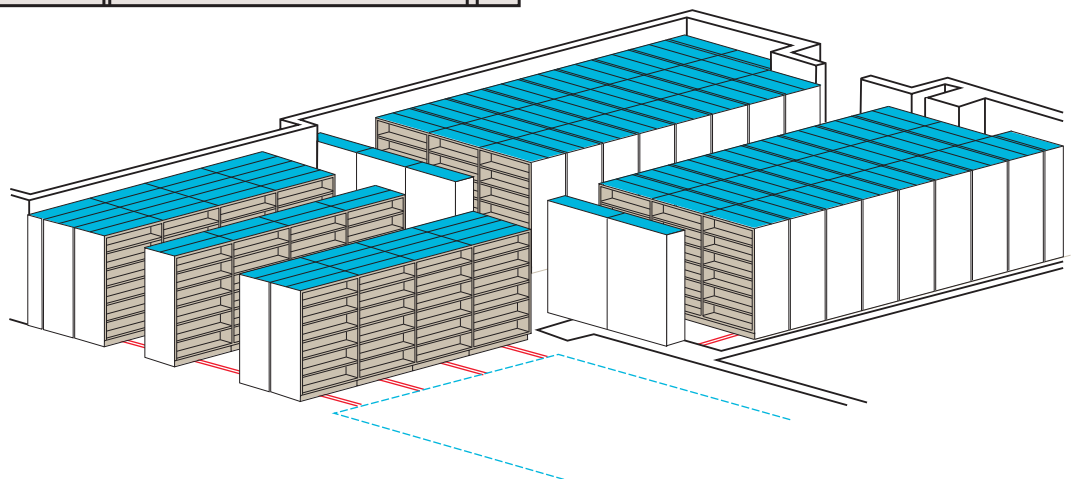
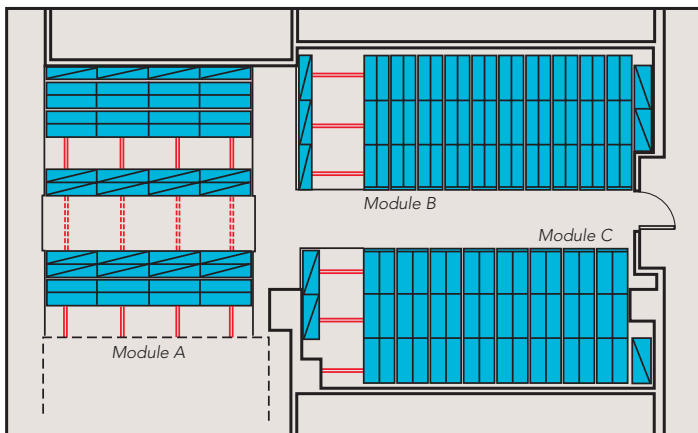

COMPACT STORAGE

ADAPTIVE REUSE OF EXISTING BUILDINGS UTILIZING COMPACT STORAGE

Existing buildings such as gymnasiums and warehouses often have sufficient floor to ceiling height to allow for a new floor to be added within the existing building. The new framed floor can be designed to support a Spacesaver high-density mobile storage system. The ground floor can also be used to house a Spacesaver system, as well as office space and ancillary space.

Your local Spacesaver Area Contractor can assist you in planning an adaptive reuse of an existing building, as well as assist you in obtaining the proper building design and construction professionals.

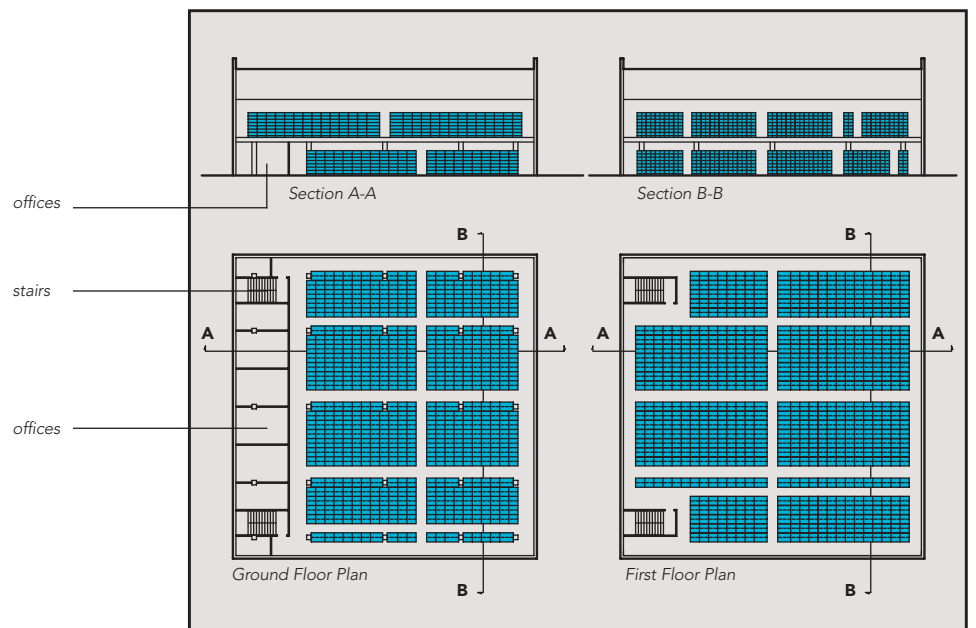
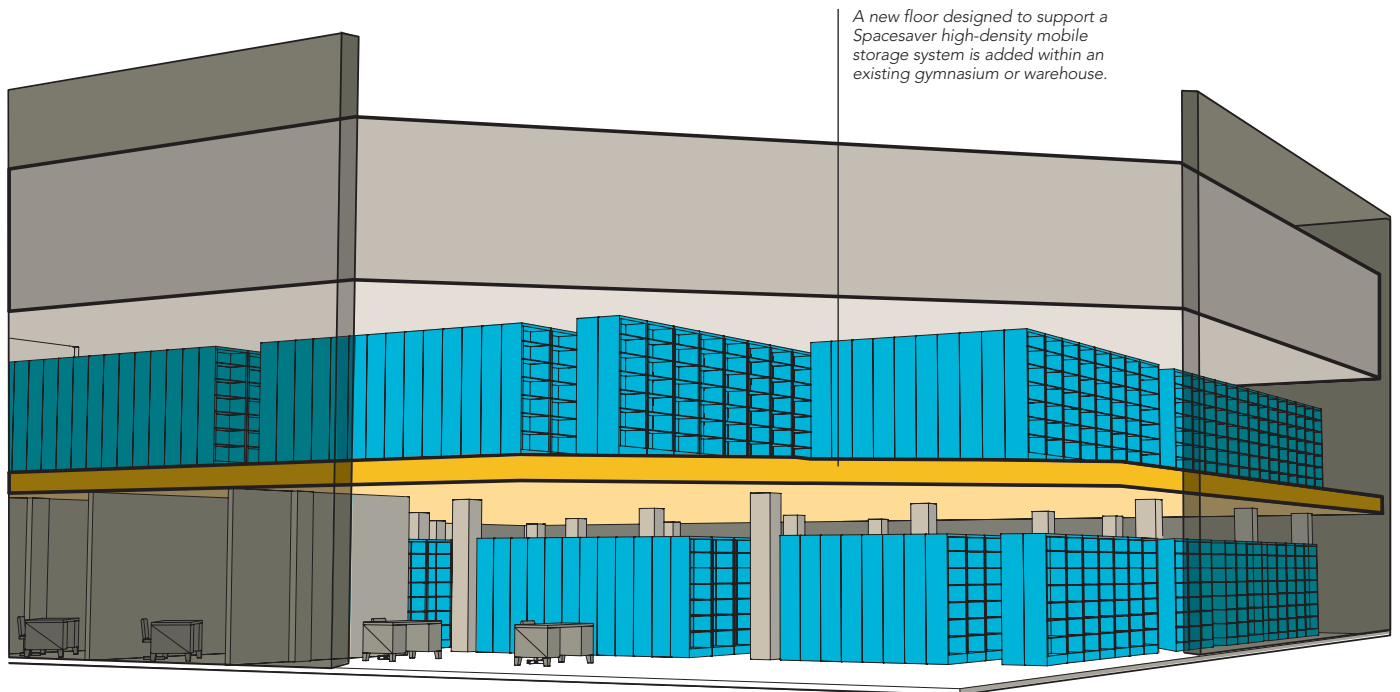

SIZE MINIMIZED

NEW BUILDING SIZE MINIMIZED BY UTILIZING COMPACT STORAGE

Spacesaver high-density mobile storage systems can contribute significant cost savings for clients who carefully pre-plan their projects. This is particularly true for new libraries, archives and museums, which offer an excellent opportunity for incorporating Spacesaver systems into their designs. In some instances, whole buildings have been designed around the Spacesaver concept. For example, the Library building addition at the University of Illinois was specifically designed around a cluster of Spacesaver systems. Without compact mobile systems, building expansion would have needed to be twice the size of the one actually built to accommodate the volume capacity that Spacesaver provided for the University of Illinois.

University of Illinois Library, Champaign, Illinois

Architects: LZT Associates, Peoria, Illinois

Spacesaver Area Contractor: Bradford Systems Corporation, Chicago, Illinois



Illustration shows building expansion that accommodates compact mobile storage. In new construction, designing the building frame to accommodate compact storage can dramatically reduce the size of new buildings or additions.

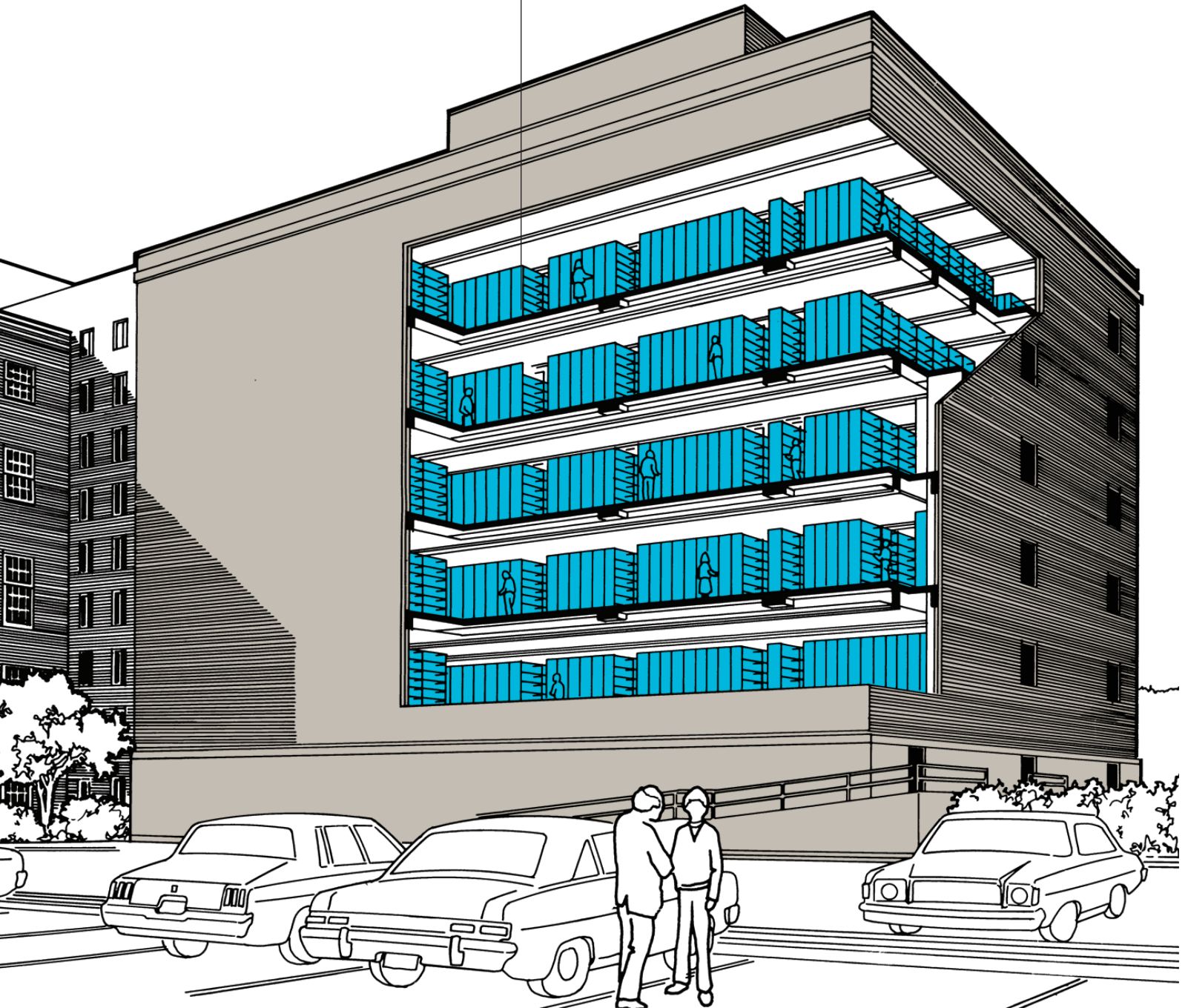



Spacesaver Corporation
1450 Janesville Avenue
Fort Atkinson, WI 53538-2798
1-800-492-3434
www.spacesaver.com



KI
1330 Bellevue Street
P.O. Box 8100
Green Bay, WI 54302-8100
1-800-424-2432
www.ki.com

Spacesaver Corporation is a division of KI.

KI is a registered trademark of Krueger International, Inc.

Spacesaver is a registered trademark of Spacesaver Corporation.

© 2013 KI and Spacesaver Corporation. All Rights Reserved. Litho in USA. FLRLOADING_0812_broch (SC-0321)